

Topic: Chromatography

**The “stuff” you do before you analyze a “complex”
sample**

Paper: 202 Biostatistics and Bioinformatics

M. Sc II Semester Zoology

Dr. HEMANT SAMADHIYA

SCHOOL OF STUDIES IN ZOOLOGY

JIWAJI UNIVERSITY GWALIOR

Separation is needed before analysis

- Homogenous appearance, biological samples are complex mixture of different substances.
Example: (a) green plants mixture of different pigments. (b) Black ink is a mixture of different colored materials.
- Due to complexity of mixture & presence of interfering substances, it is difficult to analyze the target / desired components, even after using modern tools of biology.
- Thus removal of interference & separation of desired components is necessary.
- Some of these materials can be separated by the methods given in following table.

Methods of Separation

Physical & Mechanical: Hand picking, blowing, sieving, freezing & thawing, Using machine for the purpose.

Masking: Immobilization of interference as non-reactive complex

Mechanical Phase Separation:

- (a) Precipitation & filtration: Difference in solubility of compounds formed.
- (b) Distillation: Difference in volatility.
- (c) Extraction: Difference in solubility in 2 immiscible solvents.
- (d) Ion exchange: Difference in stability of reactants with ion-exchange resins.

Chromatography: Difference in rate of movement of solute through a stationary phase.

Electrophoresis: Difference in migration rate in an electrical field gradient.

What is chromatography?

Chromatography is a method of separation of organic & inorganic compounds so that they can be analyzed and studied.

Analysis of a compound enables to understand its role in life.

Chromatography means "color writing" .

The technique was invented by a Russian botanist in 1903 - M.S. Tswett.

He separated out pigments from green leaves using a glass column.

Chromatography is such an important technique: 2 Nobel prizes awarded.

Over 60% of chemical analysis is done with chromatography or its variation.

It is based on differential migration: solutes migrate & resolve on a stationary phase through a mobile phase. Solutes with a greater affinity to mobile phase will move faster than the solutes that have more affinity to the stationary phase.

As the solutes move through the stationary phase they separate.

This is called chromatographic development.



What is Chromatography?

Chromatography is the ability to **separate** molecules using **partitioning** characteristics of molecule to remain in a stationary phase versus a mobile phase. Once a molecule is separated from the mixture, it can be isolated and quantified.

Can chromatography identify components?

Not without the detector – chromatography is the process of separation!

Why is chromatography called chromatography?

First application by **M. S. Tswett** 1903

For the separation of plant pigments. Since the components had different colors the Greek *chromatos*, for *color*, was used to describe the process.

So, the detector was not needed?

IT WAS!!! YOU ALWAYS NEED A DETECTOR TO IDENTIFY chromatographically separated COMPONENTS.

In this case, the detector is an eye, Similarly, a nose can be used for a chromatography of fragrances.



Chromatography : Different Terms, Components & Phases

- **Stationary phase:** Or Chromatography surface on which target substances get separated or resolved.
- **Mobile phase:** Or solvent or carrier which flows over the stationary phase & carries target substances along with. Sometimes it is known as developer.
- **Chromatograph:** Or chromatogram is the system of result for observation & analysis when work is done
- **Resolution:** Differential separation of components.
- **Detection:** Methods that enable to observe or detect the separated components
- **Types:** Different types on the basis of stationary phase formate
- **Basically 2 main types:** (a) Planer – Paper, TLC (b) Column
- **Mechanism (Principle):** (a) Adsorption (b) Partition (c) Ion exchange (d) Exclusion (e) Affinity
- **Mobile phase):** (a) Liquid (2) Gas (3) GLC (4) HPLC
- **Direction of flow:** (a) Ascending (b) Descending
- **Dimensions:** (a) Single d (b) 2 – D, (c) Radial

The general principle.

- Use - to separate and identify components of mixtures.
- Several different types - paper, thin layer, gas-liquid.
- All use the principle of "partition"-affinity between two phases, to separate mixtures of substances.
- Stationary phase & mobile phase.
- Compounds with greatest affinity for mobile phase travel further.

Chromatography basics

- *Mobile and Stationary phase*
- *Retention - Migration*
- *Bands or zones*
- *Equilibrium!*
- *Column vs. planar*
- *Liquid vs. gas vs. SF*
- *High vs. low resolution*
- *Partition*
- *Adsorption*
- *Ion exchange*
- *Size exclusion*

All chromatography needs:

- support material - stationary phase
- solvent (or **carrier gas**) - mobile phase.

Chromatography Type	Stationary phase	Mobile phase
Paper	Paper	Organic or aqueous solvent.
Thin layer	Silica gel supported on plastic film	Organic or aqueous solvent.
G.L.C.	High boiling point liquid on inert solid support.	Inert gas e.g. nitrogen.

Chromatography

A. Column Chromatography,

B. Planar Chromatography – Paper chromatography / TLC

General Classification	Specific Method	Stationary Phase	Type of Equilibrium
Liquid chromatography (LC) (mobile phase: liquid)	Liquid-liquid, or partition	Liquid adsorbed on a solid	Partition between immiscible liquids
	Liquid-bonded phase	Organic species bonded to a solid surface	Partition between liquid and bonded surface
	Liquid-solid, or adsorption	Solid	Adsorption
	Ion exchange Size exclusion	Ion-exchange resin Liquid in interstices of a polymeric solid	Ion exchange Partition/sieving
Gas chromatography (GC) (mobile phase: gas)	Gas-liquid	Liquid adsorbed on a solid	Partition between gas and liquid
	Gas-bonded phase	Organic species bonded to a solid surface	Partition between liquid and bonded surface
	Gas-solid	Solid	Adsorption
Supercritical-fluid chromatography (SFC) (mobile phase: supercritical fluid)		Organic species bonded to a solid surface	Partition between supercritical fluid and bonded surface

Column Chromatography

Chromatographic Separation

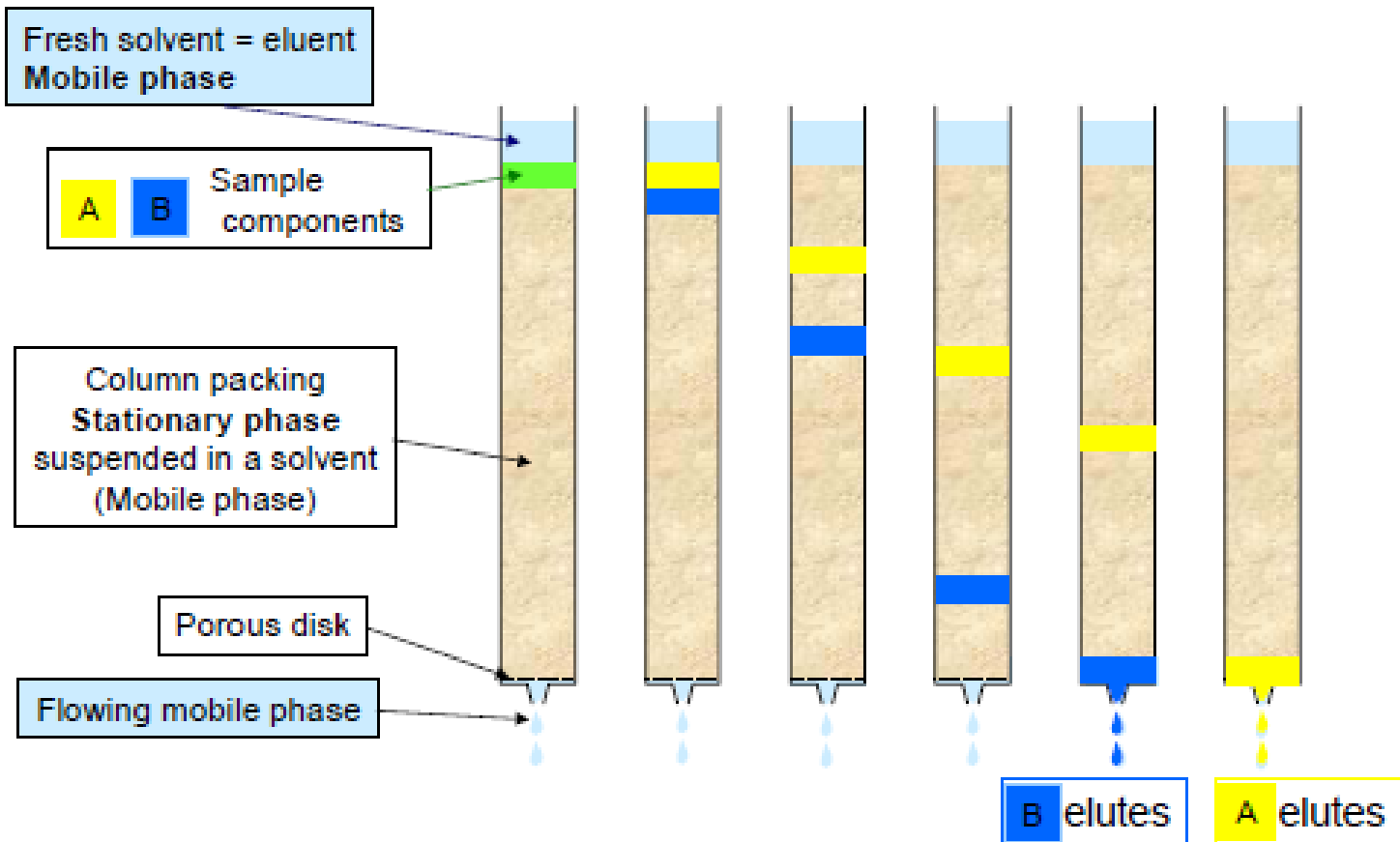

chromatogram



Chromatography: Peak separations

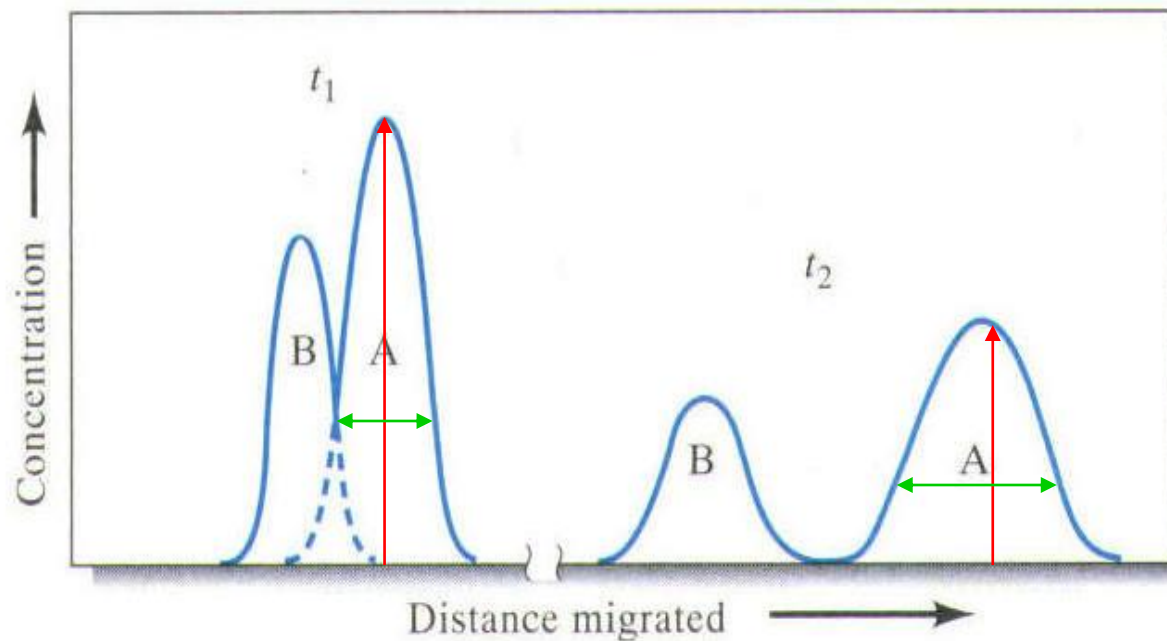

Chromatography: Peak Resolution

Poor resolution

More separation

Less band spread

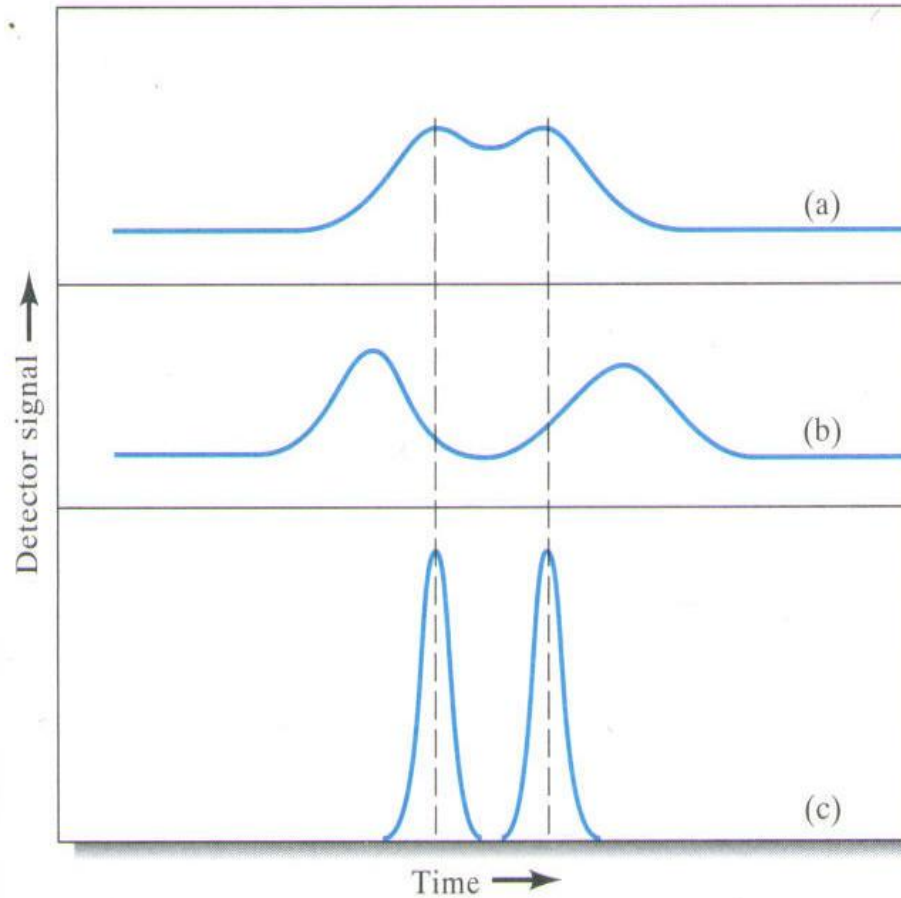

Quantitative Analysis

- Peak areas
- Peak height
- Calibration and standards
- Internal Standard method

Summary

- ❖ Relate to column chromatography
- ❖ Retention times
- ❖ Velocities of mobile and component
- ❖ Height equivalent of theoretical plates
- ❖ Peak or zone broadening
- ❖ Resolution

What happens in practice.

- Compounds that have **high affinity for mobile phase emerge first, (most volatile)**.
- Chromatogram charts recorder response against time.
- Each component - separate peak.
- **Retention time** - characteristic of the compound under given conditions.

Factors affecting retention time:

- *length of column*
- *packing material*
- *type of carrier gas*
- *flow rate of carrier gas*
- *temperature of column.*

Separation and identification.

Component **B**
has greater
affinity for
mobile phase.
Gets carried
further.

Component **A**
has greater
affinity for
stationary
phase. Does
not get carried
so far by
mobile phase.

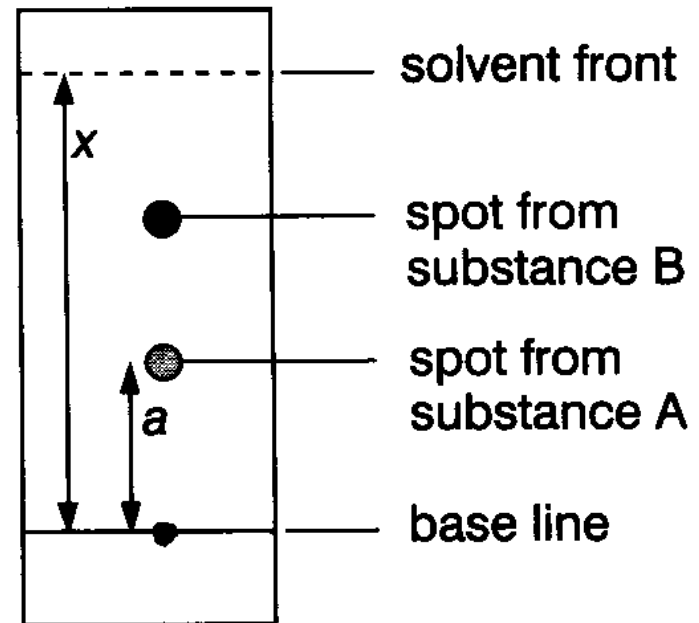
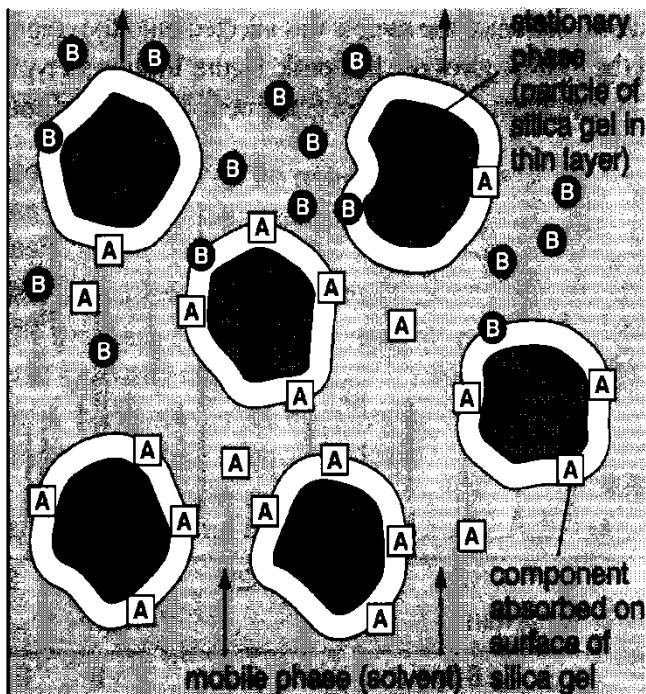

$$R_f \text{ value for substance A} = \frac{a}{x}$$

Thin Layer Chromatography - TLC

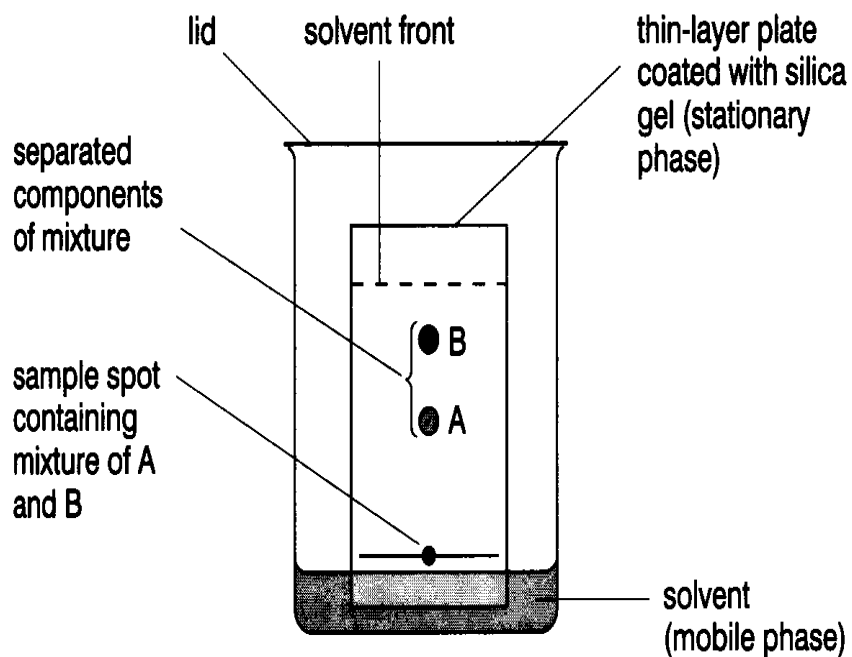

- Series of spots forms
- Compare samples in mixture with known substances.
- Measure R_f values.
- Coloured compounds & colourless compounds.

Gel-filtration chromatography: proteins passed over a column filled with a hydrated porous beads made of a carbohydrate or polyacrylamide polymer [large molecules exit (elute) first]

Ion-exchange chromatography: separation of proteins over a column filled with charged polymer beads (bead +charge = anion-exchange; bead -charge = cation exchange). Positively charged proteins bind to beads of negative charge & vice versa. Bound proteins are eluted with salt. Least charged proteins will elute first.

Affinity chromatography: proteins are passed through a column of beads containing a covalently bound high affinity group for the protein of interest. Bound protein is eluted by free high affinity group.

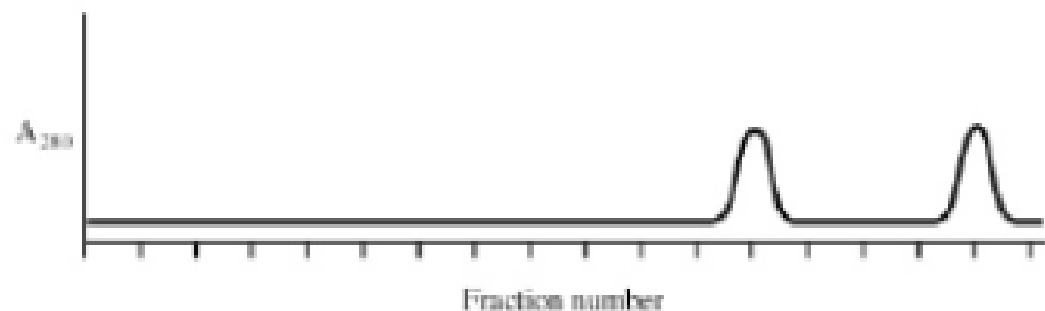

Size Exclusion (gel filtration)

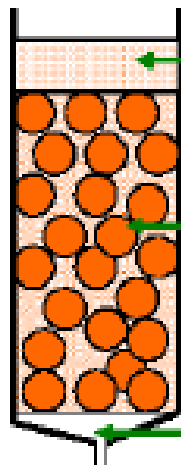

Wait for gel to settle before equilibrating with elution buffer. Make sure gel does not run dry.

Step 2

Prepare gel slurry and pour it gently into column avoid introducing air bubbles

Step 1

Fill the column with elution buffer and ensure that air spaces are eliminated from the column

Sephadex G-50 1-30 kD

Sephadex G-100 4-150 kD

Sephadex G-200 5-600 kD

Bio-Gel P-10 1.5-20 kD

Bio-Gel P-30 2.4-40 kD

Bio-Gel P-100 5-100 kD

Bio-Gel P-300 60-400 kD

Sephadex is a trademark of Pharmacia.

Bio-Gel is a trademark of Bio-Rad.

Biochemists refer to a protein's size in terms of its molecular weight, in kDa (a kilodalton, kD or kDa, is 1000 times the molecular mass of hydrogen)
Each amino acid residue counts for about 110 daltons, that is, about 0.11 kDa.

Size Exclusion (gel filtration)

V_t or total column volume

Refers to total volume occupied by the gel in the column, and not the size of the column

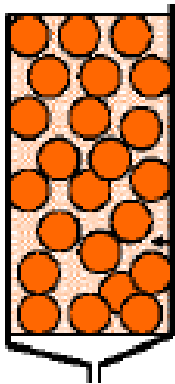

V_t = Total column volume

V_o or void volume

Void volume = space outside the granules

Rule: $V_o = 1/3$ column volume

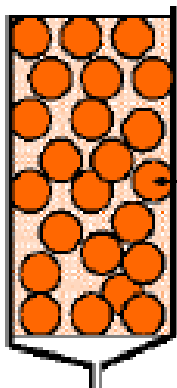

$V_t - V_o$ = volume occupied by gel space, including gel matrix (V_{gel})

Stationary phase (V_s) = $V_t - V_o - V_{gel}$
This is difficult to measure

V_s also labeled as V_i

$$K_d = \frac{V_e - V_o}{V_s}$$

$$K_{av} = \frac{V_e - V_o}{V_t - V_o}$$

V_e = elution volume of solute

V_o = void volume of column

V_s = volume of stationary phase (= V_i)

V_i = $V_t - V_o - V_{gel}$ matrix.

For convenience, expression K_{av} is used

Gel-Filtration Chromatography – Separation based on size

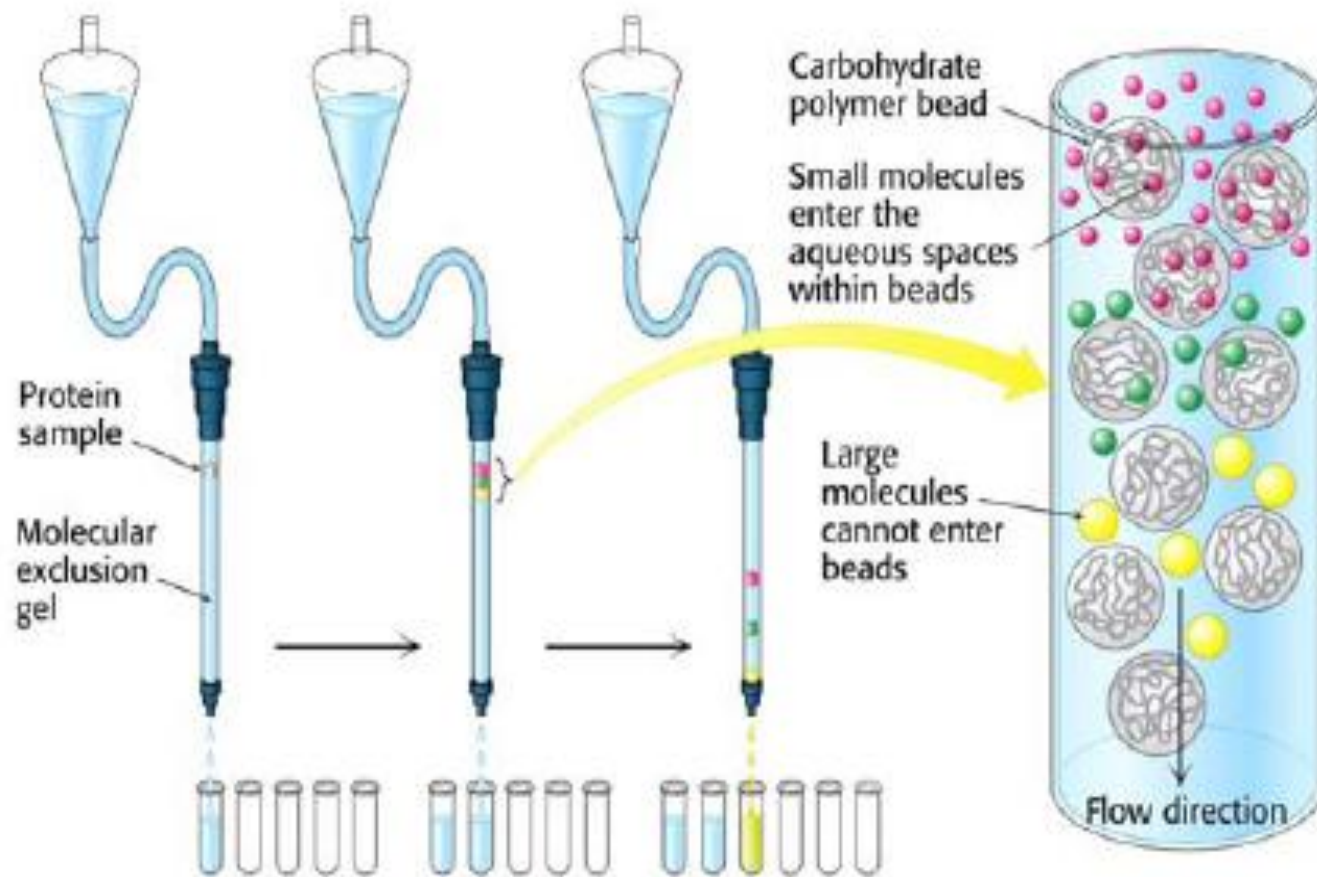

Ion Exchange Chromatography

Two common examples of ion exchangers are:

Anion exchanger:

Inert Matrix—CH₂—CH₂—NH(CH₂CH₃)²⁺ diethylaminoethyl (DEAE) group

Cation exchanger:

Inert Matrix —CH₂—COO⁻ carboxymethyl (CM) group

The inert (uncharged) matrix is
most commonly cellulose or agarose

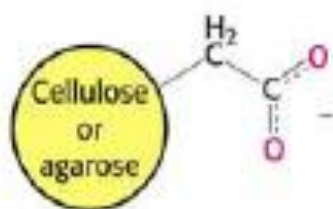

Carboxymethyl
(CM) group
(ionized form)

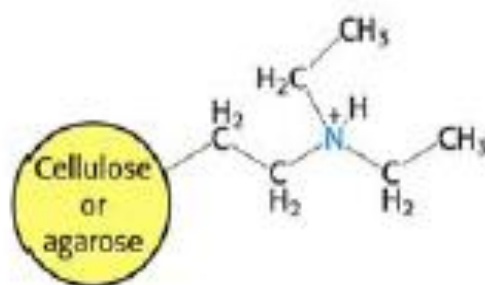

Diethylaminoethyl
(DEAE) group
(protonated form)



Positively charged
protein binds to
negatively charged
bead

Negatively charged
protein flows
through

- ❖ The surface of a protein has both positive and negative charges, and therefore can bind to both cation and anion exchangers.
- ❖ The binding affinity of a protein depends on:
 - a. the concentration of salt ions in the mobile phase that compete with the protein for binding to the ion exchanger.
 - b. the pH of the mobile phase, which influences the ionization (and therefore the charge) properties of the protein.
- ❖ A protein can be eluted from the matrix by applying a buffer at higher salt concentration (or different pH) that reduces the protein's affinity for the matrix.

pH vs pI

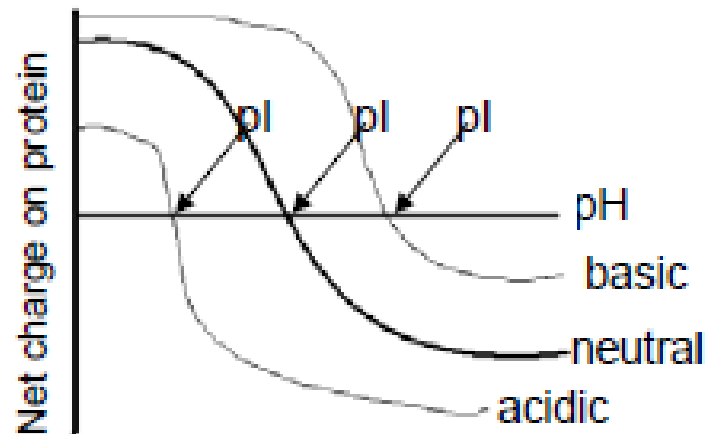

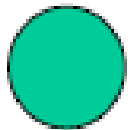

60 Kd
pI 4.2



20 Kd
pI 5.4



20 Kd
pI 6.0



5 Kd
pI 8.5

- Ion-exchange column chromatography separates proteins on the basis of charge.
- pH 7.2
- positively charged column

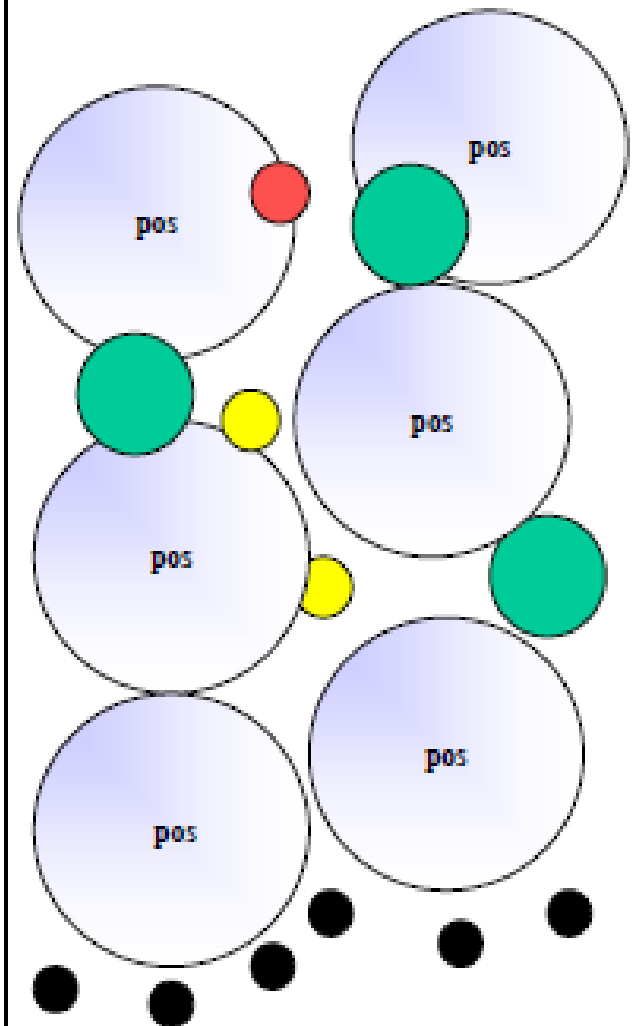

Affinity Chromatography

Small molecules are attached to beads and complex protein mixtures are applied.

Bound proteins can be eluted with the small molecule or with denaturing reagents (urea, guanidine, etc.)

Glucose-binding protein attaches to glucose residues (G) on beads

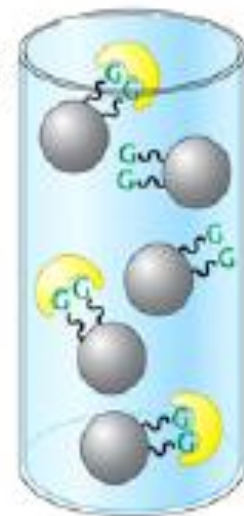

Addition of glucose (G)

Glucose-binding proteins are released on addition of glucose

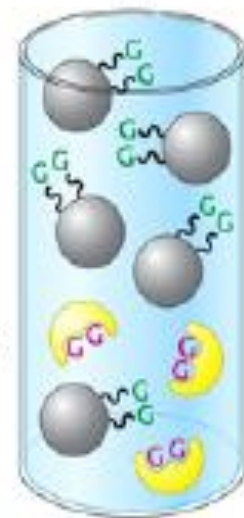

Hydrophobic Interaction Chromatography

Stationary phase: Non-polar (octyl or phenyl) groups attached to an inert matrix

Exposed hydrophobic regions on proteins will bind to similar groups on the resin

Possible elution strategies:

1. Decreasing salt concentration (since higher salt augments hydrophobic interactions)
2. Increasing concentrations organic solvents

High Pressure Liquid Chromatography (HPLC)

- *sample is vaporized and injected;
- *moves through a column containing stationary phase under high pressure;
- *separates mixture into compounds according to their affinity for the stationary phase

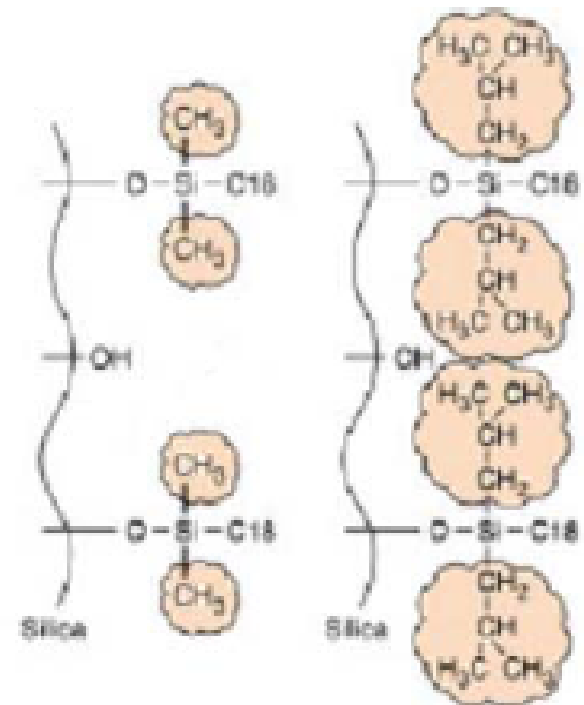

High Pressure Liquid Chromatography

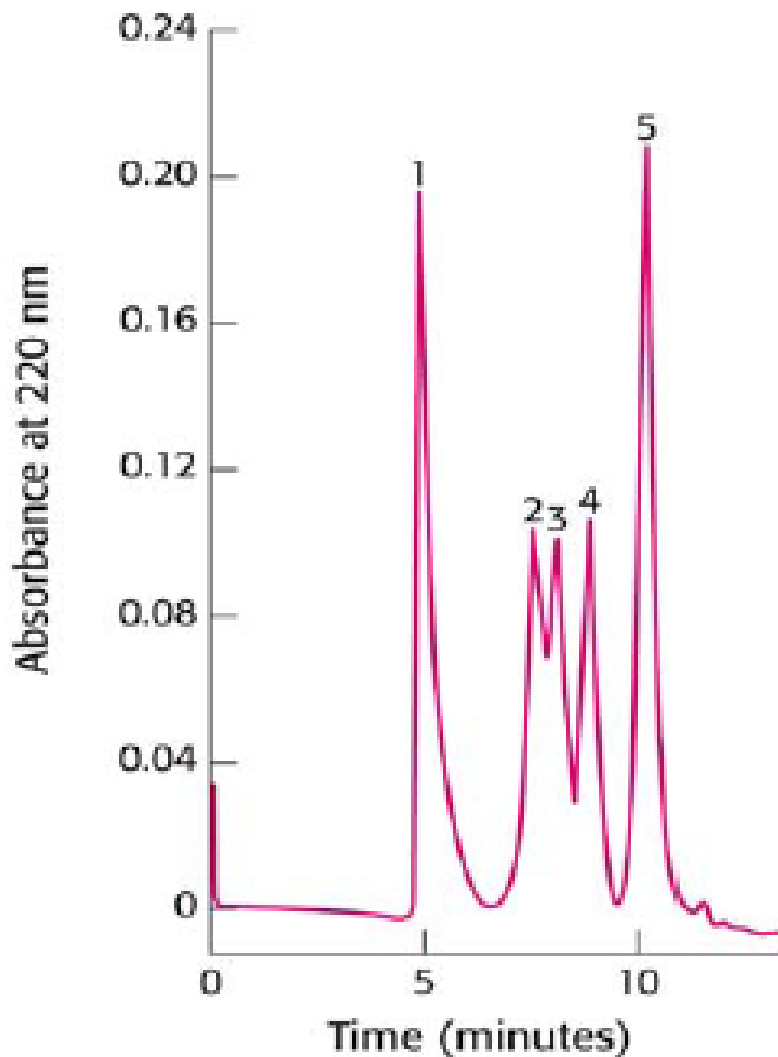

High pressure limits diffusion and increases interactions with chromatography media

HPLC gives very high resolution of protein components

- HPLC Columns:
 - Stainless steel
 - 10-30 cm long
 - 4-10 mm internal diameter
 - 1-10 mm particle size - 40,000-60,000 plates/m